

Changing Trends with Field Programmable Analog Array (FPAA)

*They say change is inevitable. They say change is the one constant. And in the world of embedded microprocessors and digital design, it's certainly true – change has been fast, furious, and deliberate. But not so with analog, they say. Change is hard. Change is time consuming. Change is next to impossible. **Until now.***

The tedious and inflexible process of designing and implementing analog circuits could often take weeks or even months. And changes to ASIC or discrete design functionality in the field ...well, forget about it. Now it is going to be changed forever. The designer can design complex analog design, test and modify the design and finalize them in few hours using FPAA (Field programmable Analog Array) technology. Currently FPAA's are available which can be configured in real time which allows the designers to modify their analog design in real time.

Signal conditioning is divided in to two main sections – analog signal conditioning and digital signal conditioning. Until now digital signal conditioning is preferred over analog because of the complexity and the lack of precision involved with analog circuitry. Moreover the tolerance of devices associated with analog devices make it very difficult to calibrate. So analog signal processing requires a high level of expertise.

'The design of analog components has traditionally pivoted around low-level "clever tricks" (art or black magic?) that involve transistor layout and parameter selection, thus making virtually impossible to use higher level of abstraction' - The Art and Science of Integrated Systems Design, Alberto L. Sangiovanni-Vincentelli.

Analog design has been left in the cold as software-centric systems are developed and verified with powerful and complex design tools. Currently most of the digital processing is done through programmable logic devices like FPGA (Field Programmable Gate Arrays), CPLD's etc. Absent of analog equivalent of FPGA has kept analog out of dialog between programmable devices and EDA tools.

A Field-Programmable Analog Array, usually abbreviated FPAA, is the analog equivalent of the FPGA. This reduces the complexity of analog design and reduces the time required for design analog circuit from months to minutes. The reconfigurable feature of FPAA's enables repurposing and real time updating of analog functions within the system.

Anadigm's field programmable analog arrays (FPAAs) introduces the ability to translate complex analog circuits to a simple set of low-level functions, and thus to give designers the analog equivalent of an FPGA. Anadigm's FPAA elevates the design and implementation process of analog design to high levels of abstraction.

By providing the analog equivalent of logic gates, FPAAs give designers the ability to describe analog functions such as gain stages and filters without reference to the underlying function - in other words, without having to think on the level of such components as op amps, capacitors, resistors, trans-conductors, and current mirrors. Lifted to this higher level of abstraction, the design process becomes so simple that non-specialists can create sophisticated circuits that would require weeks or months of design work with ASICs or discrettes.

Dynamic configurability adds to these capabilities by allowing analog functions to be updated in real time using automatically generated C-code. With analog functions under the control of the system processor, new device configurations can be loaded on the fly, allowing the device's operation to be "time-sliced," or to manipulate the tuning or the construction of any part of the circuit without interrupting operation of the FPAA, thus maintaining system integrity.

FPAA Architecture

A FPAA, is the analog equivalent of the FPGA. Unlike the FPGAs, which contain a large number of modules and interconnections allowing arbitrary configurations of combinatorial and sequential logic, FPAA devices typically contain a small number of CABs (Configurable Analog Blocks). The resources of each CAB varies widely between different commercially available and research devices. FPAAs directed toward standard analog design typically feature a CAB containing an operational amplifier, programmable capacitor arrays (PCAs), and either programmable resistor arrays for continuous-time circuits or configurable switches for switched-capacitor circuits. Anadigm FPAA family is based on switched capacitor architecture.

Switched Capacitor Technology

The switched capacitor technology is the technique by which an equivalent resistance can be implemented by alternatively switching the inputs of a capacitor. The figure given illustres how switched capacitors are configured as resistors.

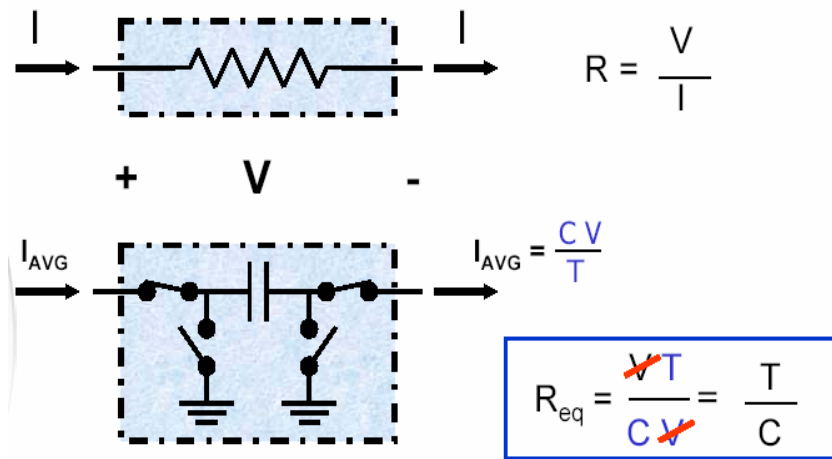

How switched capacitors act as negative resistors is shown below.

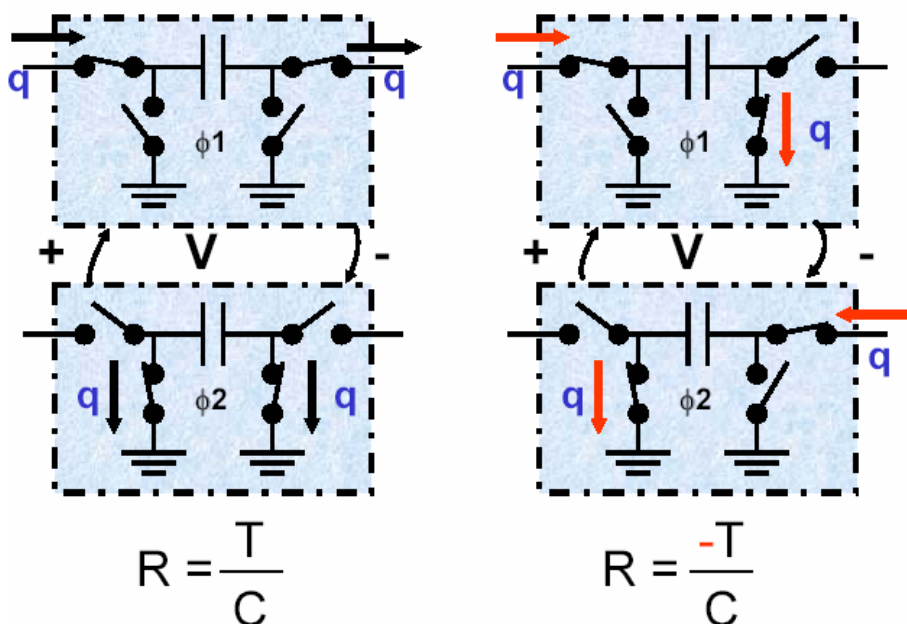

The sign of transfer functions can be changed by changing the clocking phase of the sample clock. Rectifier without diode drop can be implemented by controlling the phase based on the input signal.

Switched Capacitor circuits works on the principle of sampled data systems. The input and output signals are sampled and will be valid only during one phase. The sampling of input and output signals using switched capacitors is shown below

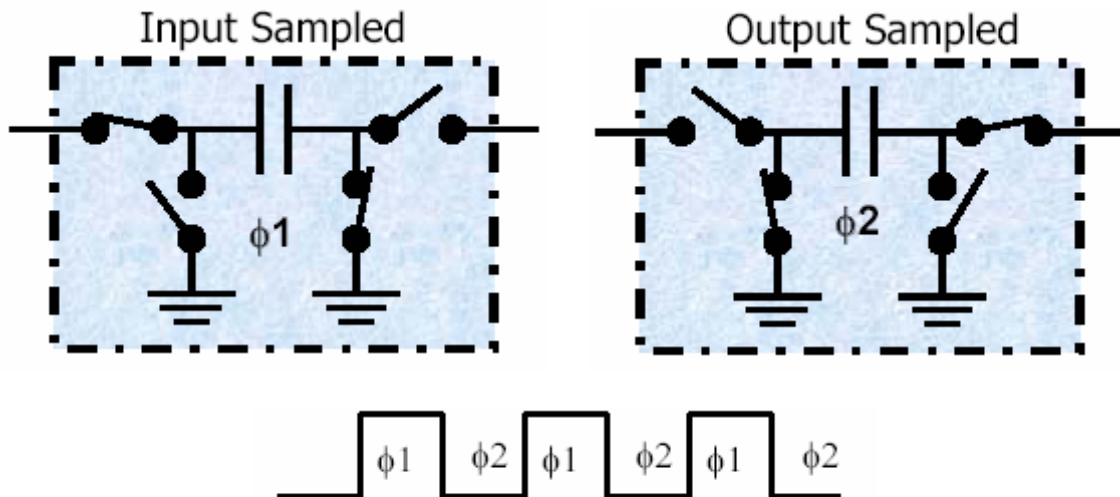

The figure below shows how a continuous time signal is converted into a sampled data signal. Sampled data signal is also an analog signal, because it can take any voltage value.

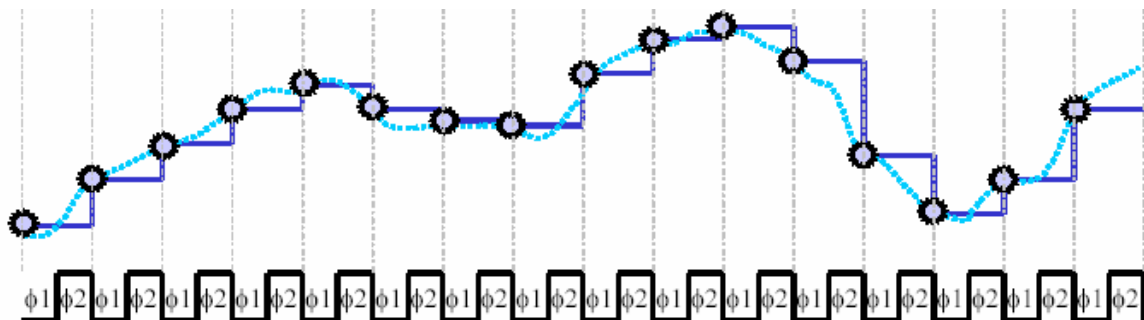

Advantages:-

- Much larger resistance value for a given area
- Temperature and process independent ratio
- Transfer function with "Negative resistors"
- Corner frequencies scale linearly with sample clock
- Better "Resistor" value
 - Better Tolerance
 - Better matching
 - Better temperature co-efficient
 - Better voltage linearity
 - Wide Range

o Anadigm FPAA Architecture

The AN221E04 device consists of a 2x2 matrix of fully Configurable Analog Blocks (CABs), surrounded by a fabric of programmable interconnect resources. Configuration data is stored in an on-chip SRAM configuration memory. Compared with the first-generation FPAA's, the Anadigm vortex architecture provides a significantly improved signal-to-noise ratio as well as higher bandwidth. These devices also accommodate nonlinear functions such as sensor response linearization and arbitrary waveform synthesis. The analog designs that can be implemented in an FPAA is done through CAM's (Configurable analog Modules). These CAM's uses the resources of CAB. The various CAM's are amplifiers, filters, comparators, multipliers, differentiators, integrators, dividers etc. These CAM's can be connected together to form the desired analog systems. Cam's parameters can be configured in real time the capability of dynamic configuration. The architecture of AN221E04 is shown below.

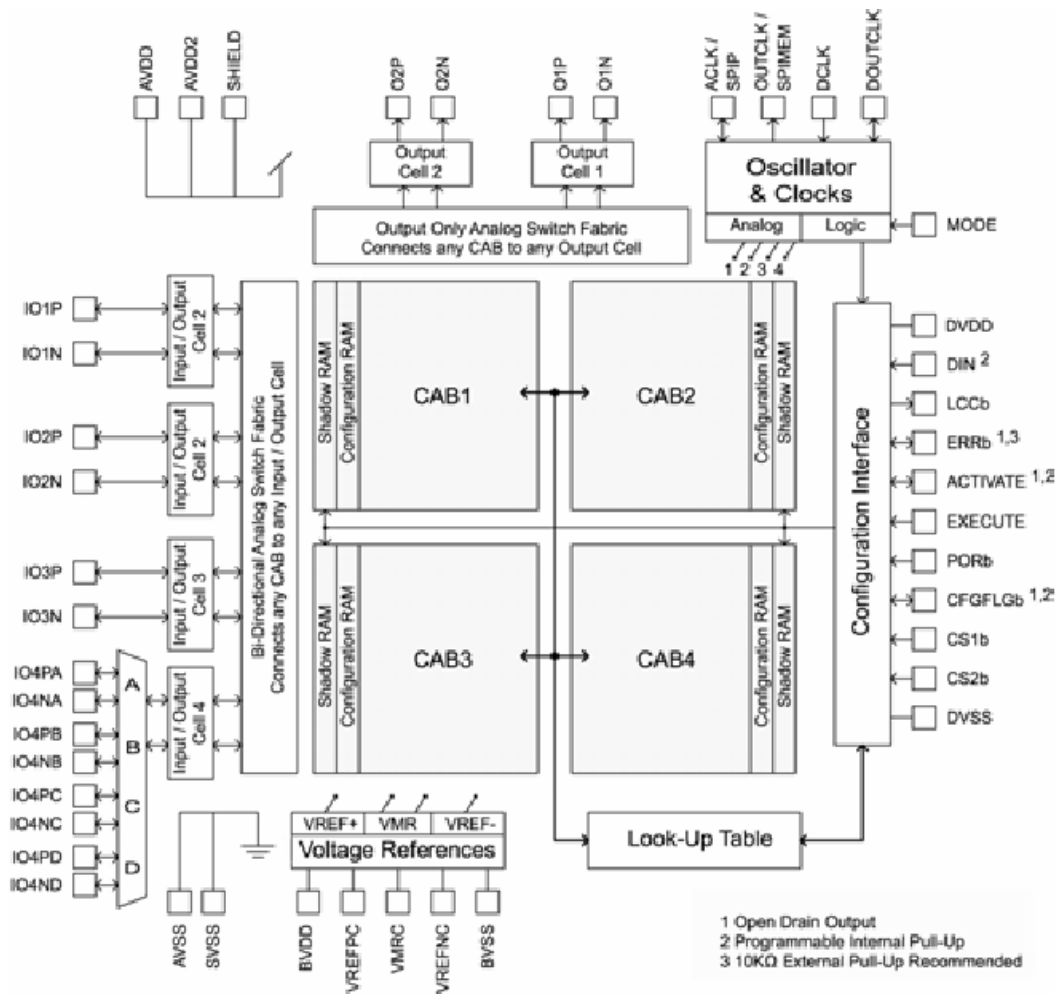

The AN221E04 device features an advanced input/output structure that allows the FPAA to be programmed with up to six outputs – or triple the number provided by the ANx20E04 devices. The AN221E04 devices have four configurable I/O cells and two dedicated output cells. For I/O-intensive applications, this means a single FPAA can now be used to process multiple channels of analog signals where two or more such devices were previously needed. Out of the four configurable input/output cells one is of 4:1 multiplexer type. The architecture of the input cell of AN 221E04 is shown below.

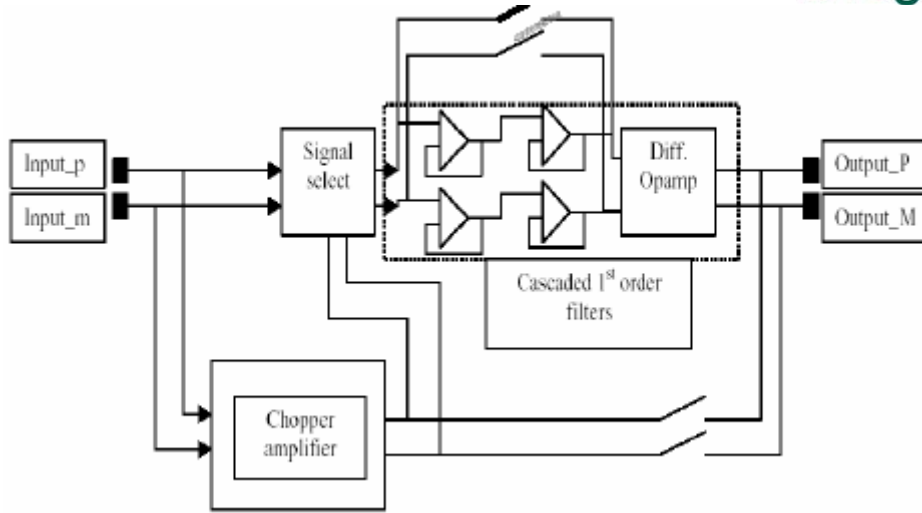

The input cells of AN221E04 FPAA can be configured as a differential input cell as well as a single ended differential input. Input cell itself consists of configurable amplifiers (chopper amplifier and unit gain differential amplifier) and anti aliasing filters. The stabilized chopper amplifier allows an DC offset down to 100uV. Anti aliasing filter is of continuous time, second order filter type with corner frequency adjustable between 34 KHz to 470 KHz.

The architecture of output cells of an Anx21 FPAA family is shown below.

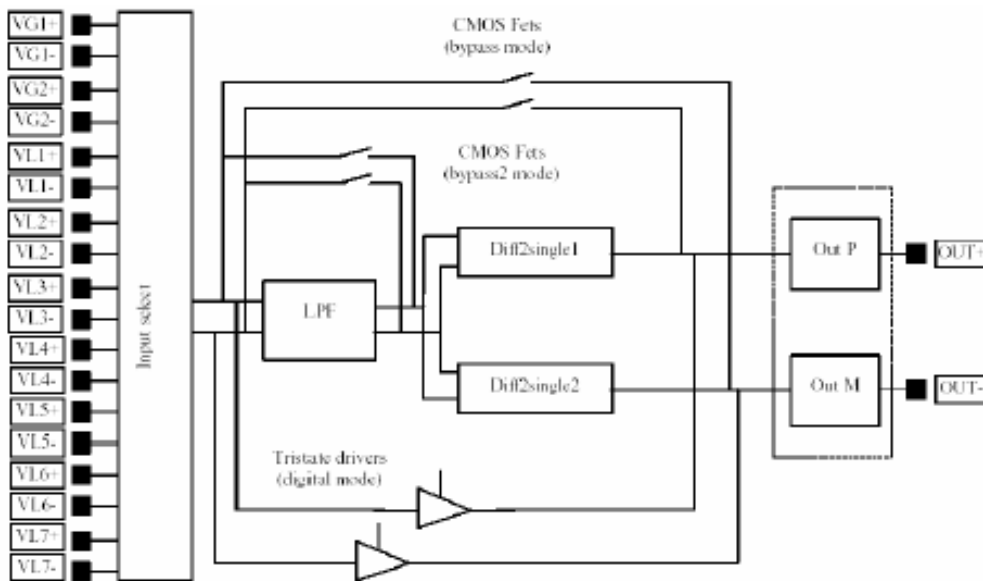

The output cell of ANx21 chip can be configured in three different modes- bypass mode, voltage output mode and digital mode. In voltage output mode, a second order, continuous time smoothing filter with corner frequency adjustable 34 KHz to 470 KHz. When digital output mode is selected, internal comparators are used.

The architecture of a CAB is shown below.

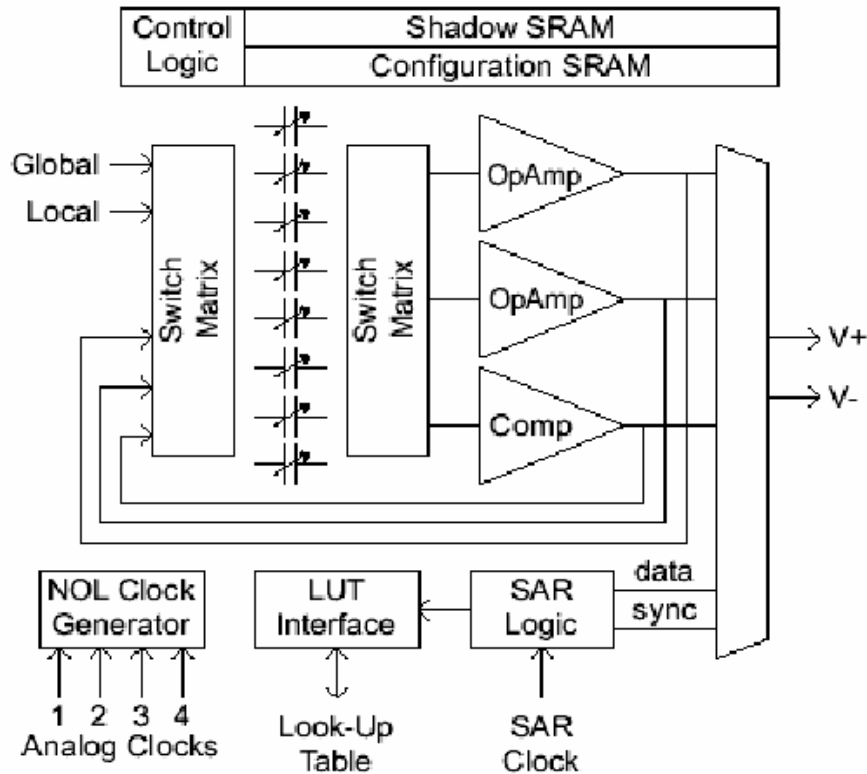

Each Configurable analog blocks of ANx21 family consists of 2 differential op-amps, one differential sampling comparator, eight (8) programmable switched capacitor banks and an 8-bit Successive Approximation Register (SAR). It also contains an 256-byte Look-Up Table (LUT) used for linearization. It also contains an extremely versatile switching and internal routing network.

ANx21 chip family contains a 256-byte SRAM LUT which is divide into 8 banks having 32 bytes each. The architecture of LUT is shown below.

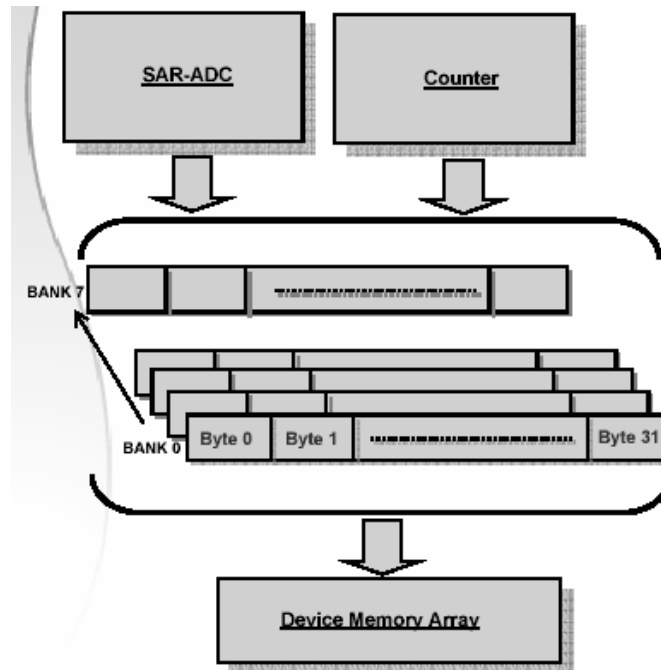

Look Up tables can be addressed from any of the SAR ADC or counters. LUT output can be used to set any value in the device memory. It can change the operation of any part of the analog array.

Look Up tables are mainly used in applications such as sensor response linearization, arbitrary waveform synthesis, signal dependent functions such as gain, frequency response, sense etc and signal companding etc.

FPAA AN221E04 Features:

- Dynamic reconfiguration
- Four configurable I/O cells, two dedicated output cells
- 8-bit SAR analog-to-digital converter(ADC)
- Fully differential architecture
- Fully differential I/O buffering with options for single ended to differential conversion
- Low input offset through chopper stabilized amplifiers
- 256 Byte Look-Up Table (LUT) for linearization and arbitrary signal generation
- 4:1 Input multiplexer
- Typical Signal Bandwidth: DC-2MHz (Bandwidth is CAM dependent)
- Signal to Noise Ratio:
- Broadband 80dB
- Narrowband (audio) 100dB
- Total Harmonic Distortion (THD): 80dB
- DC offset <100µV
- Package: 44-pin QFP
- Supply voltage: 5V

Anadigm Designer® 2

Anadigm®'s second-generation AnadigmDesigner®2 EDA tool lets you design and implement dynamically reconfigurable analog circuits within a matter of minutes. Build your circuit by dragging and dropping Configurable Analog Modules (CAMs), each of which can be used to implement a range of analog functions for which you set the parameters.

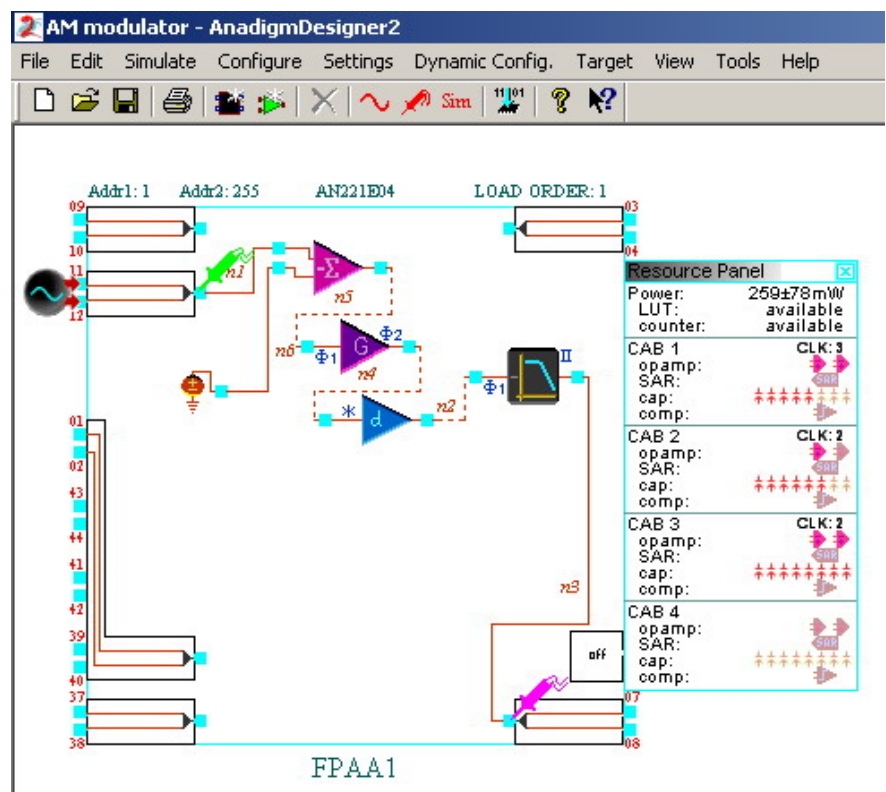

Design of Amplitude Modulator using FPAA

AnadigmDesigner®2 includes a time domain functional simulator which provides a convenient way to assess your circuit's behavior without the need for a lab set-up. The simulator's user interface is intuitive and easily learned. Most of the steps are the same that you would take while bench testing. Whether or not you're an analog expert, you can build a complete analog system rapidly, simulate it immediately and then just point and click to download it to an FPAA chip for testing and validation.

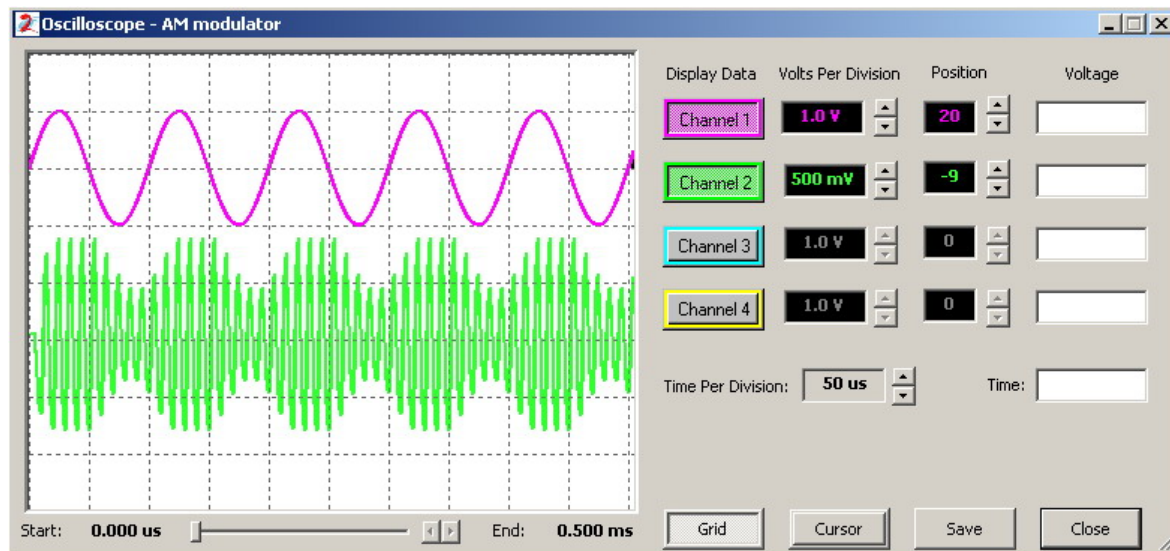

Simulation Window of AnadigmDesigner®2

AnadigmDesigner®2 is the world's first EDA product that lets you develop designs using FPAA's that can be reconfigured by the MCU in real-time to change the function they perform within a system or to adapt on-the-fly to maintain precision despite system degradation and aging. AnadigmDesigner®2 takes your design and automatically translates it into C-code that allows the design to be adjusted and controlled by a microprocessor within an embedded system. That means you can now control and adjust analog functions using system software in real time - a breakthrough capability for the analog world!

Features of Anadigm Designer®2

- AnadigmDesigner® tools allow complex circuits to be designed with a simple drag-and-drop graphical interface
- Proven, easy-to-use design tools for analog circuit designs
- No need for analog expertise to build complete analog systems
- A growing library of reusable CAMs pre-package common analog functions
- Expert system synthesis tools AnadigmFilter and AnadigmPID. automate complex circuit design
- Circuit building blocks are abstracted to a functional level that can be manipulated in AnadigmDesigner®2
- Build complete analog systems rapidly, simulate immediately, and then download to the chip for instant verification
- Built-in multi-chip time domain simulator, four-channel oscilloscope interface, and arbitrary waveform simulation
- Automatically generates C-code to allow analog functions to be adjusted and controlled directly by a micro-processor within an embedded system

Applications

FPAA has wide application in diverse fields like Audio, Telecom, Signal Conditioning systems, medical etc.

Complex analog filtering circuits

- Guaranteed and repeatable filter implementation
- Filter design and implementation takes minutes
- Implemented filter is drift-free and immune to aging or component variations

The implementation of complex analog filters has been made easy by the assistant tool Anadigm Filter provided along with Anadigm Designer®2. Using this tool the designer can design complex analog filter of different types – Butterworth, Chebyshev, Bessel function, Elliptical etc for all types of filter. Using this tool, the designer can set the corner frequency, Q-factor, stop band width, pass band width etc of the filter and see the transfer function. The designer can directly import the filter design into Anadigm Designer®2 from where it can be downloaded to FPAA.

Closed loop control systems

- Proportional-Integral-Derivative controllers implemented within minutes
- Low latency control

PID controller can be implemented using the AnadigmPID tool of Anadigm Designer®2. This helps the designer to design complex P or PI or PD or PID controllers. This tool also shows the block diagram of the PID controller that has been designed along with its mathematical model. In this the designer is allowed to change the proportional constant, integration and differentiation constant dynamically.

Sensor signal conditioning

- Gain, offset correction, linearization, etc.
- Stable sensor stimulus

The figure given below illustrates how FPAA can be used for signal conditioning application.

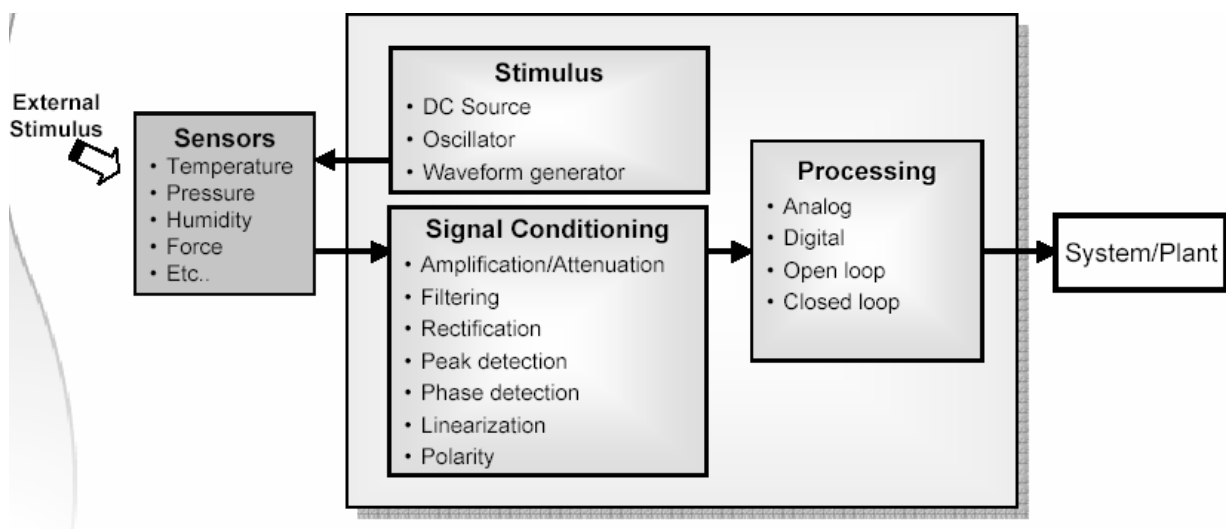

Other Applications

- Real-time software control of analog system peripherals
- Intelligent sensors
- Adaptive DSP front-end
- Adaptive industrial control and automation
- Self-calibrating systems
- Compensation for aging of system components
- Dynamic recalibration of remote systems
- Ultra-low frequency signal conditioning
- Custom analog signal processing

Benefits of FPAA Design technology

- **Simplify analog design and implementation**
 - Fully documented, repeatable analog design
 - Reconfiguration reduces design risk and allows field updates
- **Platform-based design approach**
 - Consolidate the manufacturing of multiple boards – by merely using a different configuration file
- **Consolidate of multiple discrete components on a board**
 - Reduce board space
 - Simplify manufacturing
 - Reduce inventory sourcing and management costs
 - Increase system reliability and MTBF
- **High-precision, drift-free operation**
- **Dynamic reconfiguration allows for truly innovative analog systems design**

Conclusion

With analog function under total control, new-generation dynamically reprogrammable FPAAs are ready to revolutionize the analog world.